

This document and the informations it contains are property of AMPLITUDE Tech and they shall not be reproduced, nor disclosed to any person without written consent of AMPLITUDE Tech.

Ce document et les informations qu'il contient sont la propriété de AMPLITUDE Tech et ne peuvent être reproduits, ni divulgués à toute autre personne sans l'autorisation préalable de AMPLITUDE Tech.

Dessiné/Drawn :	Evolution/Change :	Vérifié/Checked :	Date :	Rev.
--	---	--	--/--	A

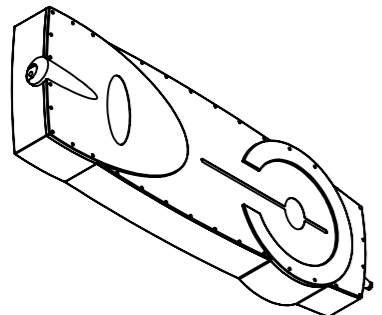
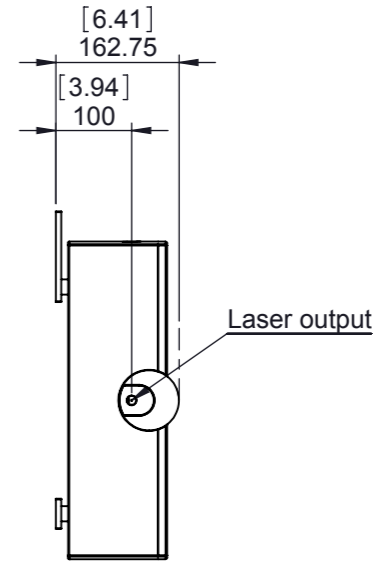
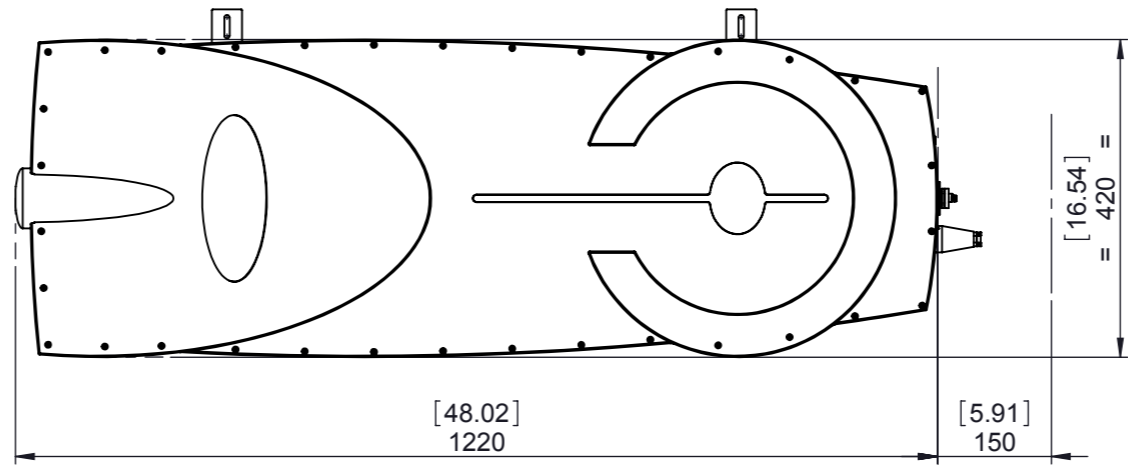
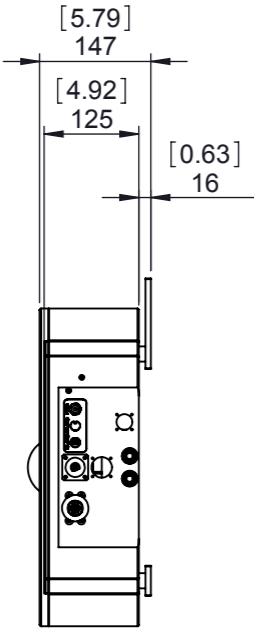
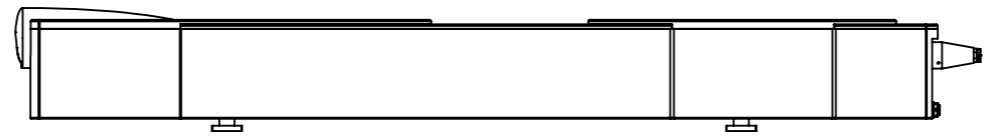
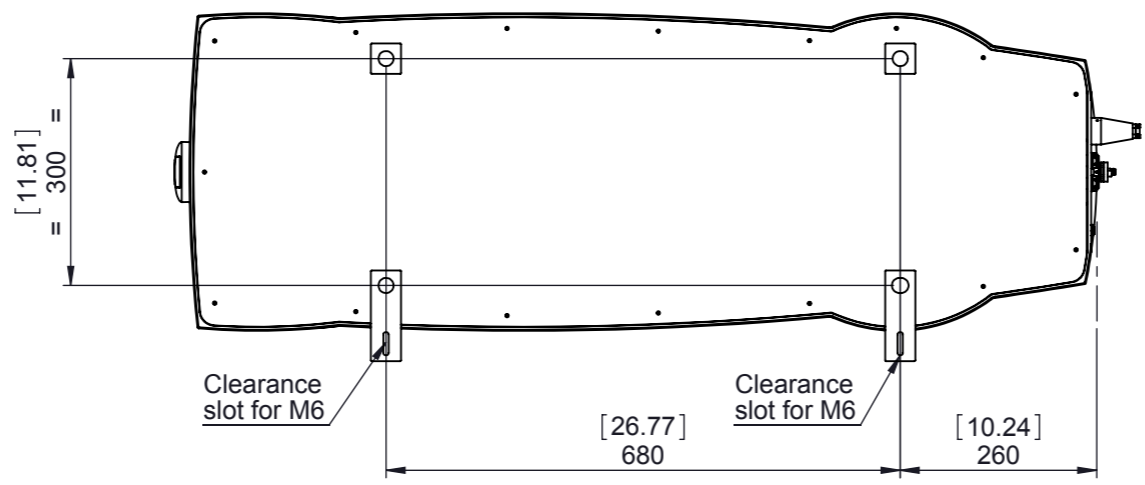

Minimal bending radius :
 Electric cable 100mm [3.94]
 Water tube 80mm [3.25]

Dessiné/Drawn : BT	Vérifié/Checked : YZ	Approuvé/Approved : RB	Date : 09/10	Quantity : 01	Reference : --
Matière/Material : ---	Trait./Treatment : ---	Tolérance / allowance : ---	Géné: Js11-js11 Part: Jsxx-jsxx	Poids/weight : --g	

Amplitude SYSTEMES
 6, allée du doyen Georges Brus
 33600 Pessac - France
 Tel. (33) 5 5646 4060 - Fax (33) 5 5646 0694
 Email info@amplitude-systemes.com
 Internet www.amplitude-systemes.com

TITRE/TITLE : --
Tangerine V2

N° Document/Document number :
PA20-0082

Echelle/Scale :
1:10

Folio/Page :
1/1