

This document and the informations it contains are property of AMPLITUDE Systèmes and they shall not be reproduced, nor disclosed to any person without written consent of AMPLITUDE Systèmes.

Ce document et les informations qu'il contient sont la propriété de AMPLITUDE Systèmes et ne peuvent être reproduits, ni divulgués à toute autre personne sans l'autorisation préalable de AMPLITUDE Systèmes.

Dessiné/Drawn : JOP	Evolution/Change : Title + informations	Vérfié/Checked : BRO	Date : 23/11/17	Rev. B
-------------------------------	---	--------------------------------	---------------------------	------------------

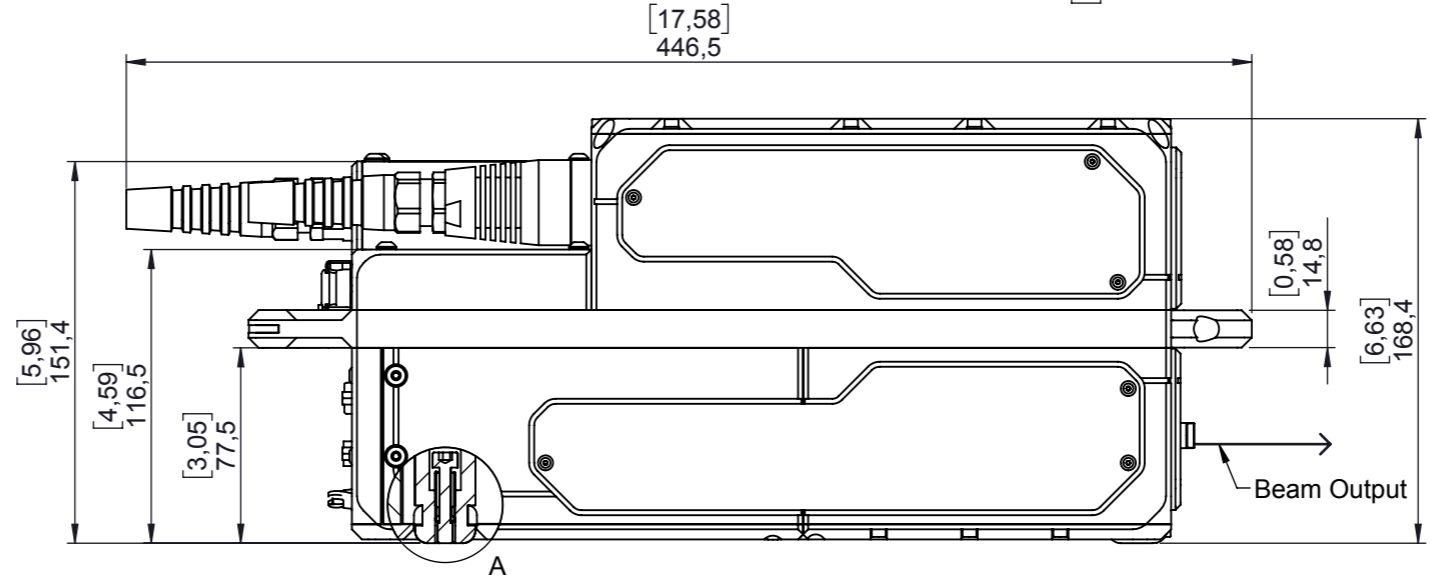
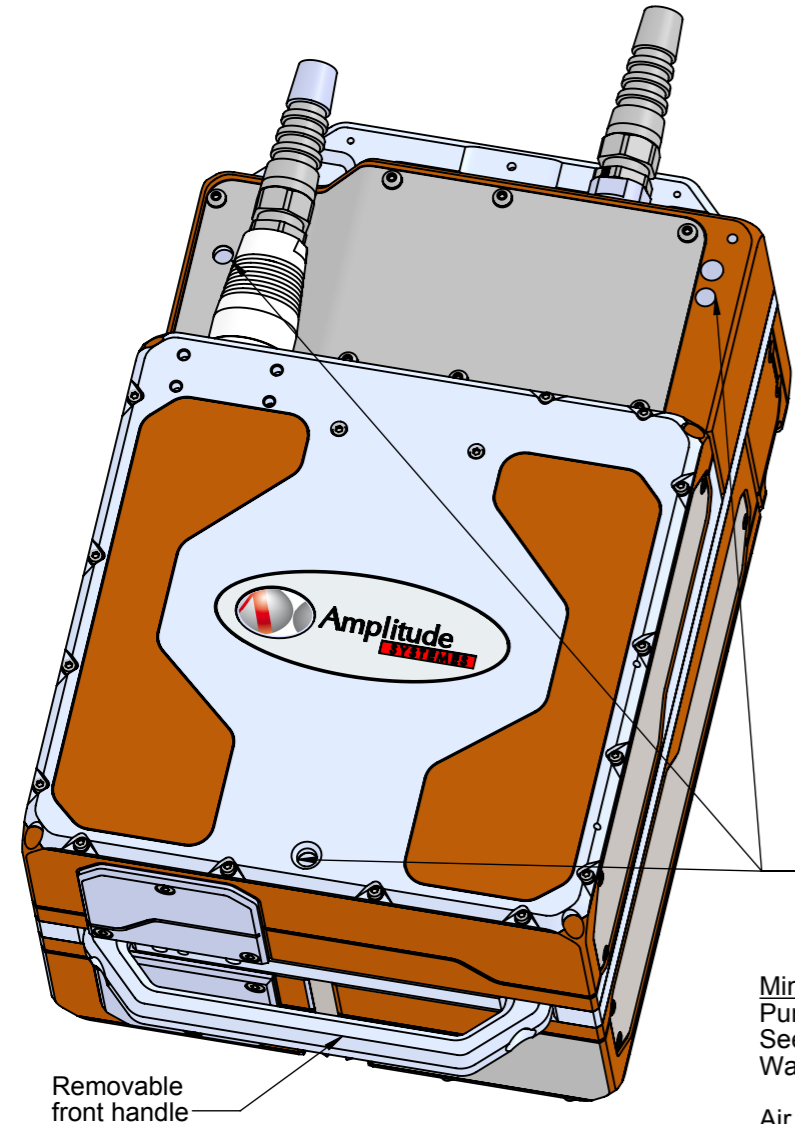
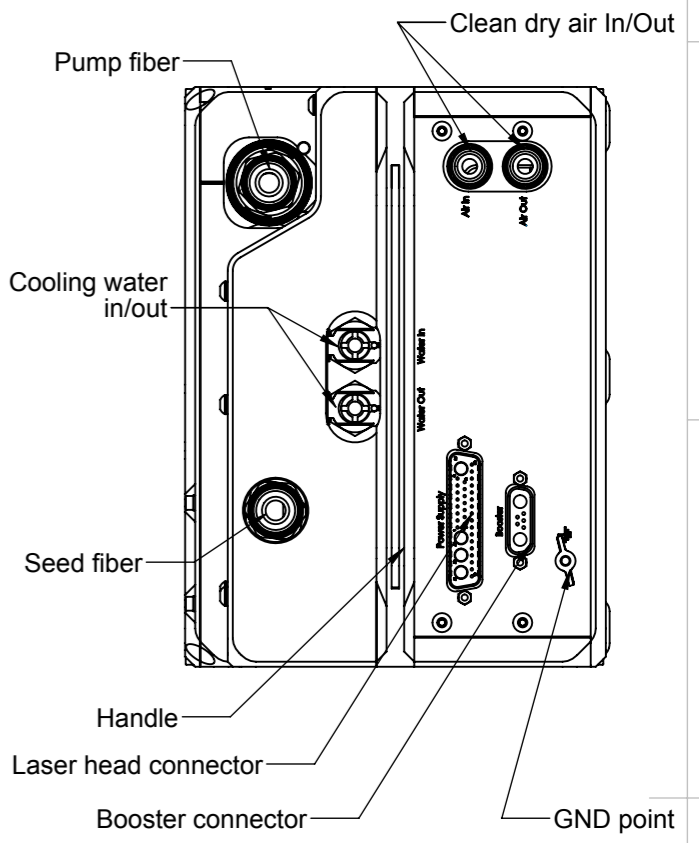
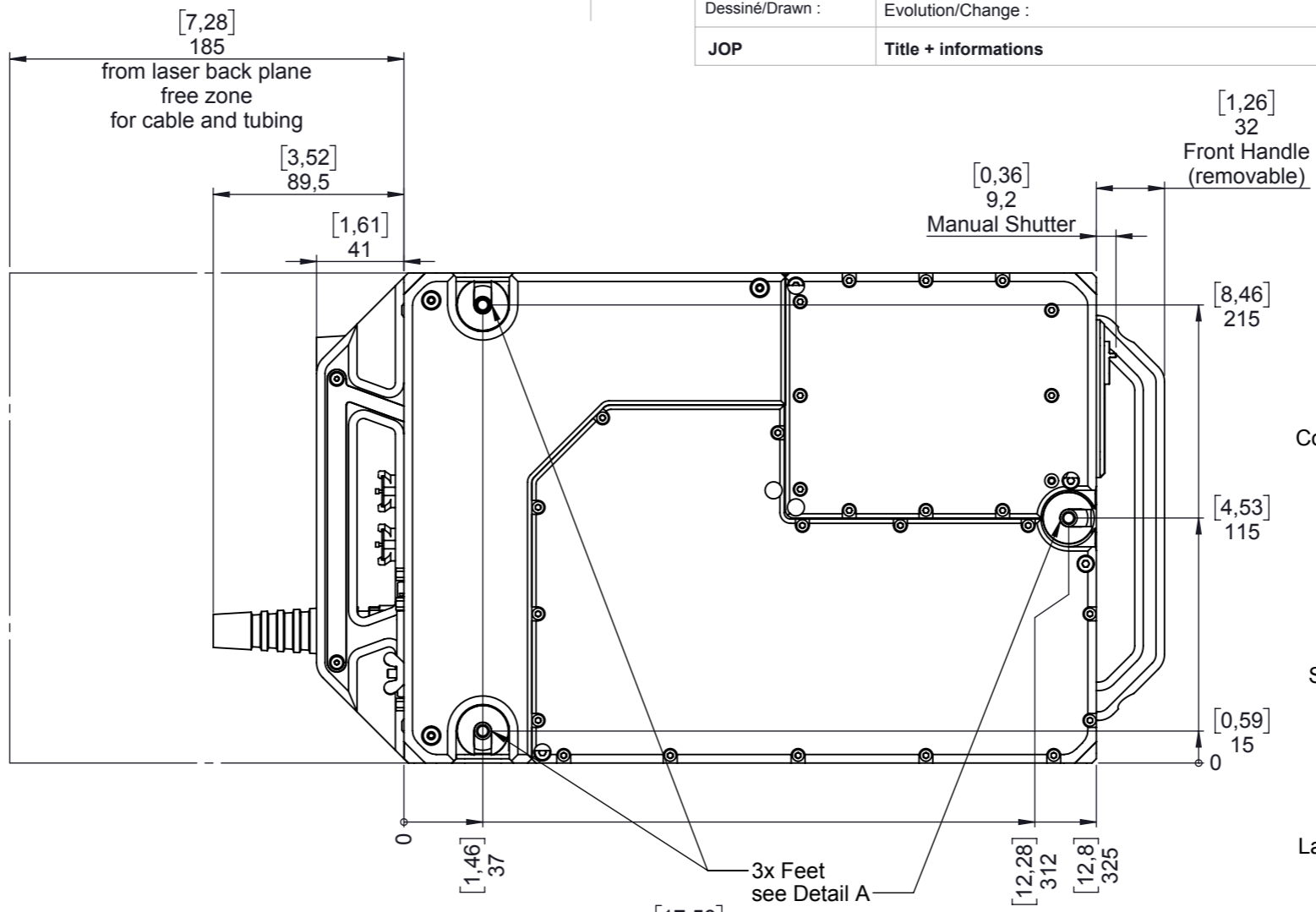
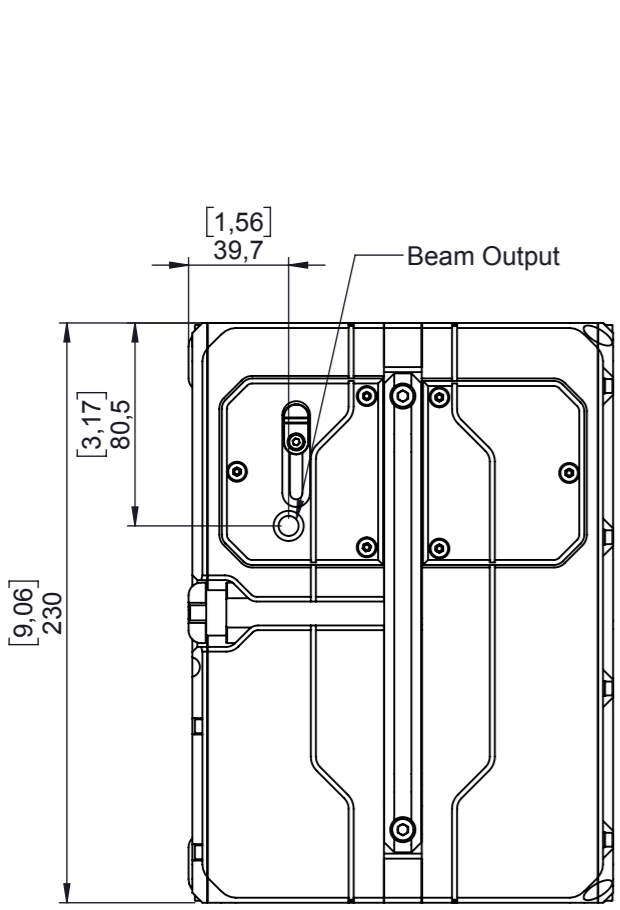

3x M6 CHC screws. Captive screws. Spring retracted.
 - Access from top (hex 5mm tool, length 150mm min.)
 - Matching mounting holes:
 - To be tapped over 10mm min. depth.
 - Use of anti-seize compound and helicoil inserts recommended.

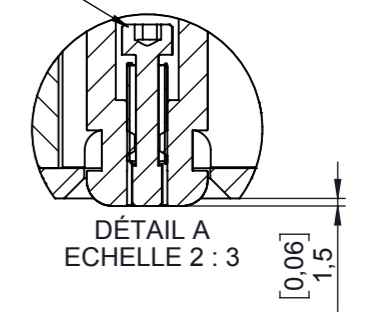

Access to 3x M6 CHC locking screw
See detail A

Minimum bend radius:
 Pump fiber: Rc=84mm
 Seed fiber: Rc=84mm
 Water tubing: Rc=90mm with 12mm O.D./10mm I.D. nylon tubing
 Rc=35mm with 12mm O.D./8mm I.D. PU tubing
 Air tubing: Rc=20mm (with 6 O.D. /4 I.D. polyurethane tubing)
 Laser head cable: Rc=90mm

Dimensions : mm [inch]

Dessiné/Drawn : FBA	Vérfié/Checked : JOP	Approuvé/Approved : ALE	Date : 10/04/2017	Poids/weight : 21 Kg	Reference : ---
Matière/Material : ---	Trait./Treatment : ---	Tolérance/allowance : ISO 2768 - mK	Rugosité /roughness : ---	Tournage : Ra0.8 Fraisage : Ra1.6	
Amplitude Cité de la Photonique, 11 Avenue de Canteranne Batiment MEROPA, 33600 Pessac - France Tel. (33) 5 5646 4060 - Fax (33) 5 5646 0694 Email info@amplitude-systemes.com Internet www.amplitude-systemes.com			TITRE/TITLE : YUJA [LASER] YUJA		
N° Document/Document number : PI27-0022-B			Echelle/Scale 1:3	Folio/Page 1/1	